

TorqueMonster Big Twin Flywheels and Crankshaft Assemblies

Truett & Osborn premium quality cast ductile iron TorqueMonster flywheels are four pounds heavier than our own stroker flywheels and five pounds heavier than stock Evos for plenty of low end torque. They're the perfect solution for restoration



*silicon bronze
wrist pin bushings*

*reciprocating rod ends
are precision weight
matched to +/- 2 grams*

*center to center rod
length and end bores
machined to +/- .0001"*

*super lightweight
rod set is forged*

*from 100%
certified 4340
heat treated steel!*

*guaranteed
unbreakable
TorqueMonster
110,000 psi
ductile iron
flywheels*

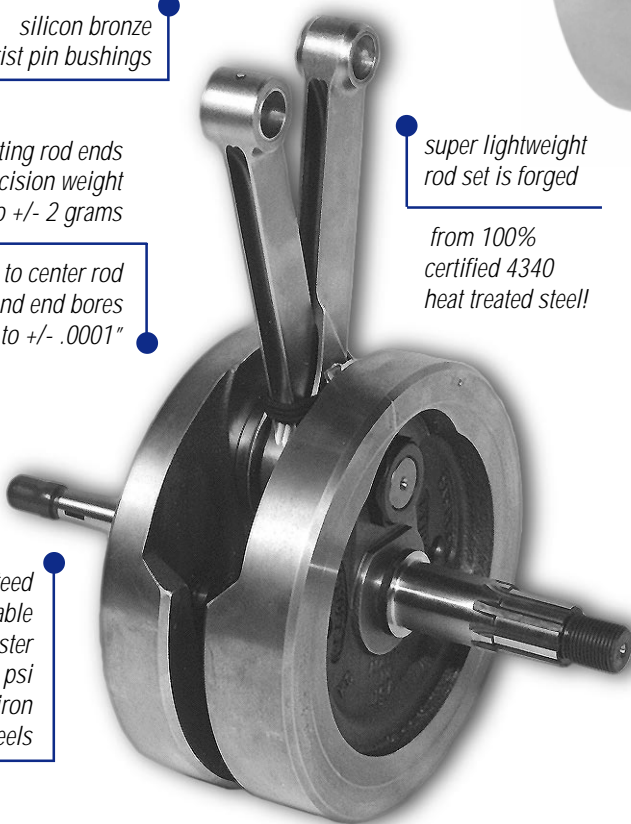

also available in standard widths

*assemblies include
dynamic balancing*

(OEM 1939-1971) projects or late model performance upgrades. Guaranteed unbreakable, all our TorqueMonster flywheels include replaceable thrust washers.

Our dynamically balanced crankshaft assembly (left) features "H"-type forged connecting rods that are heat treated, x-rayed, stress relieved, and weight matched for smooth running performance and total reliability.

This bullet-proof lower end uses a super lightweight rod set (avg. weight 1.25 kg) for strokes up to five inches.

TRUETT & OSBORN

3345 E. 31st South Wichita, KS 67216
(316)682-4781 (316)682-4853 fax